

| PART NO. | STOCK CODE | VARIANTS |
|----------|------------|----------------------------|
| BE-820C | A1827 | COLOR: MIRROR IMAGE (PAL) |
| BE-821C | A2002 | COLOR: MIRROR IMAGE (NTSC) |
| BE-822C | F2151 | COLOR: NORMAL IMAGE (PAL) |

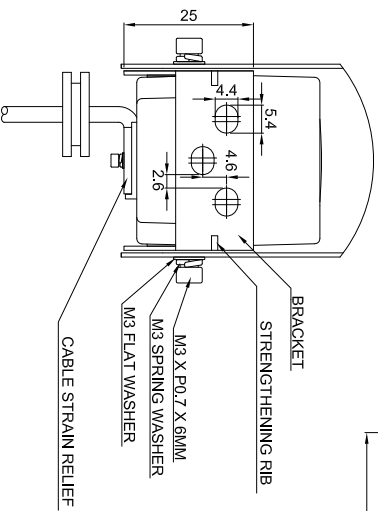

VIEW A

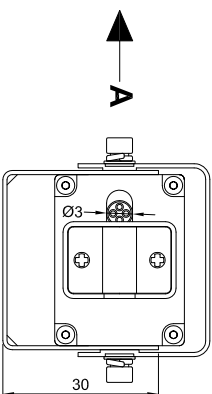
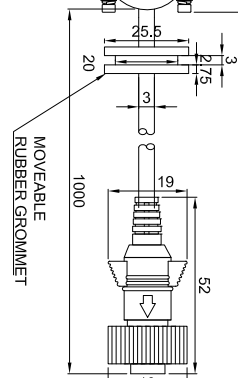
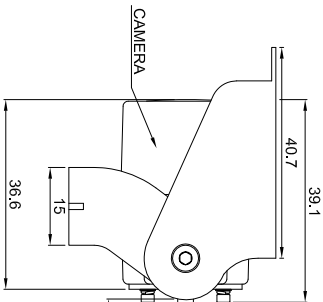
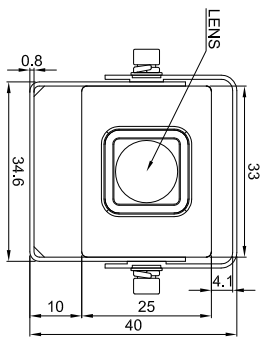
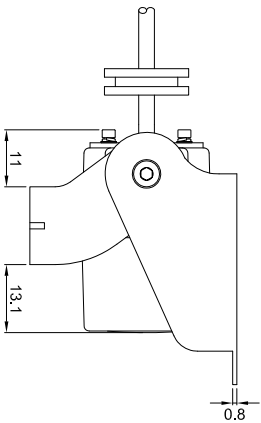
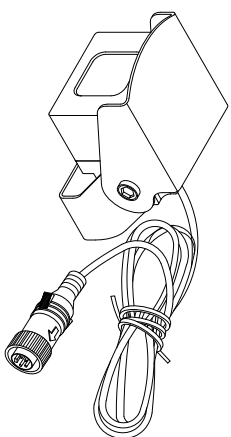
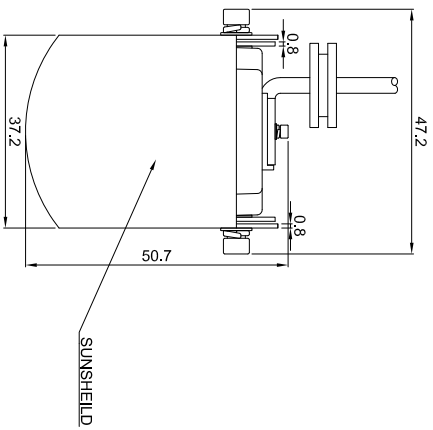
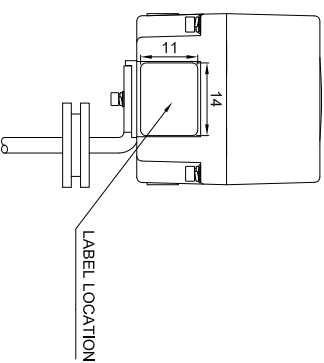
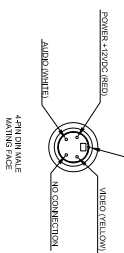

| REV NO | REVISION NOTE | DATE | SIGNA TURE | CHECKED |
|--------|---------------|------|------------|---------|
| | | | | |

PROPRIETARY NOTICE
 THIS DESIGN AND TECHNICAL INFORMATION APPEARING ON THIS DRAWING IS THE PROPERTY OF BRIGADE ELECTRONICS PLC. AND IS DISCLOSED IN CONFIDENCE. IT IS NOT TO BE COPIED, REPRODUCED, REVEALED TO OR APPROPRIATE BY OTHERS, EITHER IN WHOLE OR IN PART WITHOUT THE EXPRESS WRITTEN CONSENT OF BRIGADE ELECTRONICS PLC.

| ITEM REF | QUANTITY | TITLE/NAME, DESIGNATION, MATERIAL, DIMENTION ETC | ARTICLE NO./REFERENCE |
|-------------------------|-----------------|--|-----------------------|
| DESIGNED BY MBUTLER | | CHECKED BY DKERAI | DATE 17/02/09 |
| | | APPROVED BY SMAITHENS | SCALE N/A |
| BRIGADE ELECTRONICS PLC | | BE-821C_(A2002) | |
| | BE-000704-00-09 | EDITION A | SHEET 1/1 |